

BioSorter®

SYSTEMS SPECIFICATIONS

INTRODUCTION

The BioSorter is a large particle flow cytometer designed to analyze, sort and dispense biological materials and other objects ranging in size from 1 to 1500 microns in diameter. The system is designed to handle objects which are too large or too fragile for traditional flow cytometers. Examples include small multicellular model organisms, delicate large cells / cell clusters, small seeds and beads used as micro-carriers or for combinatorial libraries.

The BioSorter can be configured to accommodate the full 1 to 1500 micron range in five steps, each with a specially engineered Fluidics and Optics Core Assembly optimized for a particular size range. An operator can easily switch between these different modules to maximize sensitivity and speed for any given sample type.

Interchangeable Fluidics and Optics Core Assemblies:

Up to five different Fluidics and Optics Core Assemblies can be added to the BioSorter. Each fluidics module features a square cross-section quartz flow cell optimized for maximum sensitivity for a corresponding sample size range.

Flow Cell Inner Bore	Object Size Range	Recommended Object Size*	Beam Geometry at Flow Cell
FS-250 μm (forward scatter)	1-200 μm	1-40 μm	10 x 250 μm
250 μm	10-200 μm	30-150 μm	10 x 250 μm
500 μm	20-400 μm	40-300 μm	10 x 500 μm
1000 μm	30-750 μm	200-700 μm	10 x 1000 μm
2000 μm	30-1500 μm	500-1500 μm	10 x 2000 μm

* Note: these are general guidelines. Please talk to one of our Applications Scientists about your specific project / sample requirements.

Parameters Measured:

This continuous flow system is capable of quickly analyzing small and large quantities of objects using five parameters: size, optical density and up to three channels of fluorescence. Objects are passed axially, one by one, through the focus of a laser beam. The resulting signals are then detected and recorded by extinction and fluorescence detectors. Relative size is measured by the extinction detector which records the length of time that the signal from the blocked light remains above a pre-set threshold level; this parameter corresponds to the time of flight (TOF). The optical density of the object is determined by the total integrated signal of the blocked light; this parameter is the object's extinction (EXT). The fluorescence intensity (FLU) can be simultaneously determined at three different wavelengths as determined by the excitation and emission filters in the system. TOF is related to an object's axial length, EXT is related to how opaque or transparent an object is and FLU is related to the amount of fluorescence such as a GFP fluorescent tag or labeled antibodies that is present.

Sorting and dispensing decisions are based on user-selectable values for up to 21 parameters (when using Profiler™; not including derived parameters) that are entered through our FlowPilot™ or FlowPilot-Pro™ software. Objects can be dispensed into microtiter plates, tubes or bulk receptacles. Using our patented pneumatic sorting mechanism, the BioSorter instrument is gentle enough to sort and dispense fragile cells and live organisms without affecting viability.

OPTICAL ASSEMBLY DESIGN SPECIFICATIONS

BioSorter instruments are available with multiple excitation lasers and detection optics to accommodate a variety of fluorescence excitation and emission requirements. Various lasers are used as excitation sources for fluorescence. Custom optics and low dispersion lenses allow these instruments to precisely focus the excitation lasers across all flow cell sizes. Instruments have an extinction detector and three PMT (photo multiplier tube) fluorescence detectors which can be used to detect fluorescence emissions in the different regions of the visible spectrum. Interchangeable PMT filters and dichroic mirrors enable specific selection of fluorescent emission wavelengths. The standard filter set detects fluorescence in the green, yellow and red regions of the spectrum.

LASER EXCITATION SOURCE:**488 nm Solid State Laser (included)**

This 50 mW laser is standard on all instruments. It is used to measure axial length (TOF), optical density (EXT) and to excite fluorescence in objects passing through the flow cell.

Optional Solid State Excitation Sources (up to 3 may be added)

The BioSorter can accommodate up to a total of four lasers. Some of the most popular choices are listed below but other options are available so please inquire if you have a special request.

Excitation Wavelength (nm)	Power (mW)	Use (Each can also measure TOF & EXT)
405	100	Fluorescence
445	40	Fluorescence
561	50	Fluorescence
640	100	Fluorescence
660	100	Fluorescence

DETECTION OPTICS:**Extinction Detector**

The extinction detector is a PIN photo diode which detects the amount of light blocked as the object passes in front of the laser beam.

Fluorescence Detectors

Fluorescence collection optics and photomultiplier tube detectors are utilized to maximize fluorescence detection sensitivity. Optical filters allow for simultaneous detection of three fluorescence emission wavelengths as specified in the following table. These filters and dichroic mirrors can be configured to precisely select specific regions of fluorescence. One example of a filter setup is shown in the table below:

	Example Fluorescence	Detection Range
PMT 1	GFP	498 – 522 nm
PMT 2	YFP	532 – 556 nm
PMT 3	Cy5	665 – 695 nm

OPTIONAL DETECTION OPTICS:**Optional Fluorescence Detector Filters**

Optional fluorescence detector filters are available in a variety of ranges. Some examples of common options are given in the table below; other options may also be available. These optional filters can be interchanged with the standard filters by the end user.

Fluorescence	Detection Range
ABZ	420/20 nm
NADPH	445/40 or 460/30 nm
GFP	510/23 nm
FITC / Oregon Green	535/45 nm
YFP	545/25 nm
PE	585/20 nm

<i>(Continued)</i>	
DsRed	610/20 nm
mCherry & PI	615/24 nm
Rhodamine	615/45 nm
Cy5	680/30 nm
Far Red	725/50 nm

FLUIDIC SPECIFICATIONS

Sample Cup Assemblies:

Standard Sample Cup

50 ml conical tube with suspended stir bar (40 ml working volume)

Optional Sample Cups

750 ml sample cup with suspended stir bar

2 liter sample cup with suspended stir bar

Fluid Regulation:

Sample Fluid – the sample flow is controlled to +/- 0.5% accuracy with automatic feedback pressure regulation.

Sheath Fluid – a high precision metering pump is used to deliver precise and repeatable sheath flow rates.

All other fluids are controlled by the instrument's software and electronics producing excellent repeatability and flow stability of all fluids.

Fluid Bottle Capacity:

10 Liters Sheath

10 Liters Waste

10 Liters Water

1 Liter Clean Solution

1 Liter Ethanol Flush Solution

1 Liter Hypochlorite (bleach) Flush Solution

ELECTRONICS SPECIFICATIONS

Workstation: Windows® based workstation running FlowPilot™ or FlowPilot-Pro™ software with real-time data acquisition via on-board customized electronics.

Stage: Three axes, XYZ motion stage capable of holding two microtiter plates.

Analog: Data resolution using 14 bit A/D converters and 32-bit processing resulting in 16-bit data granularity (1:65536) with data gathering speeds up to 5 MHz.

INSTALLATION

Instrument Size: 22 in (54 cm) deep x 45 in (114 cm) wide x 25 in (62 cm) tall

Fluidics Cart Size: 18 in (46 cm) deep x 23 in (59 cm) wide x 23 in (59 cm) tall

Workspace: Recommend a permanent, open, level, vibration free work space with the dimensions of 3 feet (92 cm) deep x 6 feet (183 cm) wide x 3 feet (92 cm) high.

System Weight: 150 lbs (70 kg) not including computer or Fluidics Cart

Power: 350 Watts. Place the BioSorter within 6 feet (2 meters) of the power outlets.

For USA and Canada: One single phase, 120VAC, 20 amp, 50/60 HZ, separate dedicated line with protective earth ground, using the detachable cords supplied. *If the optional Air Compressor is used, it is recommended that a second separate dedicated line (100-120VAC, 15 amp, 50/60 HZ, single phase with protective earth ground) is provided. Always ensure that local electrical codes are followed.

For Continental Europe: One single phase, 220/240VAC, 16 amp, 50/60 HZ, separate dedicated line with protective earth ground using the detachable power cords provided or CE7/VII approved equivalent detachable cords. *If the optional Air Compressor is used, it is recommended that a second separate dedicated line (220/240VAC, 10 amp, 50/60 HZ, with protective earth ground) is provided. Always ensure that local electrical codes are followed.

Pressurized Air: 25-100 psi of filtered, at 1 CFM, non-condensing, water and oil free supplied by house air or optional compressor.

Temperature: 60°F (15°C) to 85°F (30°C) environmental temperature limits. Temperature should not vary more than +/- 1 degree C from the time of experimental setup through completion. The system generates approximately 3800 BTU/Hr.

Humidity: 0 to 85% non-condensing environmental relative humidity limits.

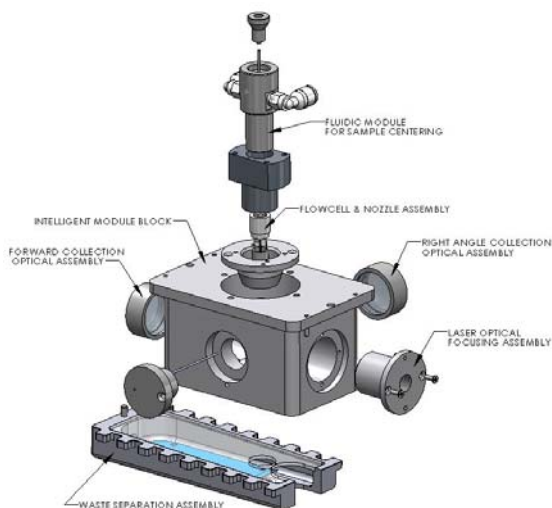

Fluidics and Optics Core Assembly



BioSorter with optional 2nd display

